

EMBEDDED SYSTEM FOR IMPEDANCE MEASUREMENT

Mr. Bhimrao Sheshrao Jadhao
PG Student, Electronics Dept.,
Walchand College of Engineering,
Sangli, India.

Mr. S. D. Ruikar
Associate Professor, Electronics Dept.,
Walchand College of Engineering,
Sangli, India.

Abstract— The purpose of this paper work is to design and implementation of an embedded system for impedance measurement. This system is design by using the impedance converter integrated circuit AD5933 which gives the real and imaginary value for measuring the impedance. The system combines an on-board frequency generator with build in 12-bit, 1 MSPS, analog-to-digital converter (ADC). There is built in frequency generator allows an external complex impedance to be excited with a known frequency. The response signal from the device testing under test (DUT) is sampled by the on-board ADC and a discrete Fourier transform (DFT) is processed by an on-board DSP engine. The DFT algorithm returns a real (R) and imaginary (I) data word at each output frequency as the real and imaginary register contents, which can be read from the serial I2C interface. The Arduino mega board microcontroller (ATmega2560) maintains control of the AD5933 via the I2C-compliant serial interface protocol. The impedance measurement range is $1K\Omega$ to $10M\Omega$ but we can measure range $1\Omega - 10M\Omega$ is enabled using additional circuitry i.e. AD8606 with reference resistor added to the unknown reactive component and correction of the real part and the phase of the measured impedance. The complex material is connected to the impedance converter IC AD5933 between VOUT and VIN Pin. The system will measure an impedance of DUT which will be displayed on LCD and for future use the impedance data would be stored into the micro SD card as data logger.

Keywords— Arduino mega board, Impedance converter, DSP engine, DFT algorithm, AD5933 and LCD display.

I. INTRODUCTION

The impedance analysis is very popular technology and now a days impedance measurement is very popular in the different field such as medical field a patient diagnosis using impedance analysis techniques, Structural health monitoring (SHM), Non-destructive testing (NDT), and bio-impedance (BI) technique. The impedance analyzer is required to measure the impedance of particular device, material and semiconductor material but available impedance analyzers are very expensive, heavier (not portable) and consume more power.

Large number of industries and researchers are working on impedance analyzer for implement the simplest one. The available impedance analyzers are not suitable for particular

application so that we are going to implement the impedance analyzer for specific application which will not be expensive. The purpose of this paper is to design and implement of an embedded system for impedance analyzer based on impedance converter IC AD5933 which is high precision impedance converter. The high precision impedance converter is based on system on chip (SoC) microsystem manufactured by analog devices. The advantages of the SoC microsystem are low power consumption, in build DFT and direct digital synthesizer (DDS). This paper is design in five section as follows section II is overview of proposed system, section III is hardware implementation, section IV is experimental result and section V is conclusion.

II. OVERVIEW OF PROPOSED SYSTEM

2.1 Proposed System

This system consists of arduino mega which an embedded board which is interfaced with the AD5933 is using I2C protocol which gives the real and imaginary value from DUT is presented in Fig.1. The arduino board will be interfaced with a micro SD card which store data from device under test in the form of will excel sheet when SD card will connect to PC. The LCD display will display the impedance data and at same time data will be stored in the SD card. The SoC microsystem has both pin which are VOUT and VIN that is used for connecting the DUT between them.

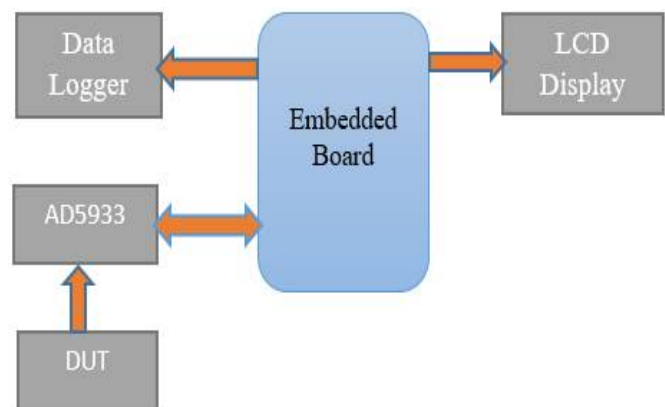

Fig 1 : Proposed System Block Diagram

2.2 Arduino Board

In this system arduino board is used as microcontroller board based on the ATmega2560 is shown in Fig.2 for processing on coming data from impedance converter IC. It mainly used as embedded board to be interfaced to the impedance converter IC.

Specification of arduino mega board are as follows:-

- Microcontroller ATmega2560
- Operating voltage 5V
- Input voltage (recommended) 7-12V
- Input Voltage (limits) 6-20V
- Digital I/O Pins 54 (14 for PWM)
- Analog Input Pins 16
- DC Current per I/O Pin 40 mA
- DC Current for 3.3V Pin 50 mA
- Flash Memory 8 KB
- SRAM 8 KB
- EEPROM 4 KB
- Clock Speed 16 MHz

2.3 AD5933 Impedance Converter

The microsystem is a high precision impedance converter system.

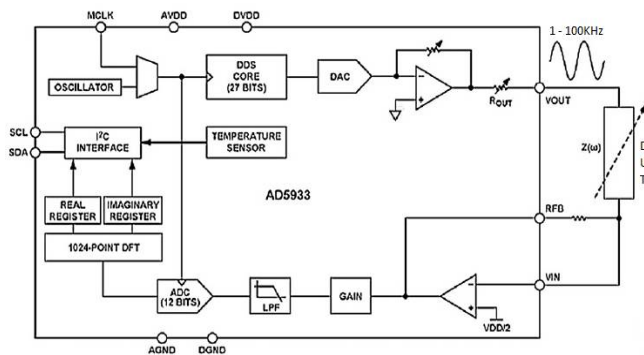

Fig 2 : Functional Block Diagram of AD5933

The AD5933 has in build frequency generator for exciting the external complex impedance with a 12 bit, 1 MSPS, analog to digital converter (ADC). The response signal from the DUT is sampled by on board ADC and discrete Fourier transform (DFT) is proposed by an on board DSP engine. The DFT algorithm returns a real (R) and imaginary (I) data word at each output frequency [1].

The main specification of AD5933 are as follows:

- Impedance range 1 K Ω – 10 M Ω .
- Output frequency range 1 – 100 KHz
- Internal oscillator frequency 16.77 MHz

- MKCL frequency 16 MHz
- Output frequency resolution 0.1 Hz
- There are four different transmit output voltage range i.e. 1.98 Vp-p, 0.97 Vp-p, 0.383 Vp-p and 0.198 Vp-p.
- Receiver stage :- input leakage current -1nA, input capacitance- 0.01pf and feedback capacitance- 3pf

2.4. Micro SD card as data logger.

Now a days, digital control system are widely used in all industries and everyday life. Data recording is very important for future used when system unfortunately is out of order that time will use the data i.e. stored in the micro SD card.

When system is measured the impedance of DUT which is displayed on LCD for observation of connected device impedance. The recorded data should be easy to read for anyone with or without technical knowledge about microcontroller. SD card need to be formatted into the FAT file system format before use. A 2 GB or less card should be formatted in FAT or FAT32. Card larger than 2 GB should be formatted in FAT32.

III. HARDWARE IMPLEMENTATION

This system schematic is designed in the Eagle7.5.0 version PCB design software. The system is based on Arduino mega2560 and AD5933 is a high precision impedance converter shown in the Fig. 4. The AD5933 is 16 pins SSOC ic is particularly design for impedance measurement by analog device. The system has in build oscillator, programmable gain amplifier (PGA), low pass filter (LFP), 12 bit, 1 MSPS ADC for sampling the impedance data and DFT for processing on sampled data.

The processed data will be input of real and imaginary register and these in the form of two's complement on the I2C protocol. The data is processed by Arduino microcontroller ATmega2560. The measured data will be displayed on LCD display and at same time will be stored in the data logger.

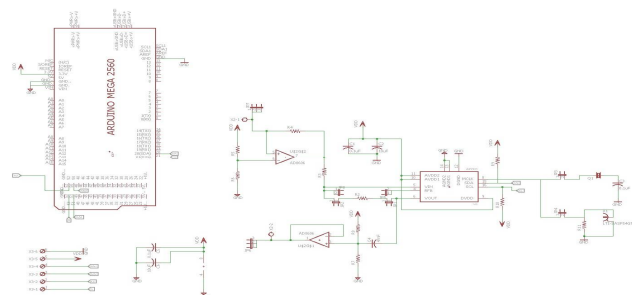

Fig 3 : Schematic of proposed system

The system is implemented on the Arduino mega board as shown in Fig. 4. The LCD is displaying the impedance result of calibration of the developed system. The system should be calibrated when frequency is vary.



Fig 4 : impedance analyzer system based on AD5933

The impedance magnitude and phase are easily calculated using the following equation:

$$\text{Magnitude} = \sqrt{R^2 + I^2} \quad \text{Phase} = \tan^{-1} \left(\frac{I}{R} \right)$$

The AD5933 permits the user to perform a frequency sweep with a user-defined start frequency, frequency resolution, and number of points in the sweep. In addition, the device allows the user to program the peak-to-peak value of the output sinusoidal signal as an excitation to the external unknown impedance connected between the VOUT and VIN pins.

The excitation signal for the transmit stage is provided on-chip using DDS techniques that permit sub hertz resolution. The receive stage receives the input signal current from the unknown impedance, performs signal processing, and digitizes the result. The clock for the DDS is generated from either an external reference clock, which is provided by the user at MCLK, or by the internal oscillator. The clock for the DDS is determined by the status of Bit D3 in the control register

Impedance Calculation

1) Magnitude Calculation:

The first step in impedance calculation for each frequency point is to calculate the magnitude of the DFT at that point. The DFT magnitude is given by

$$\text{Magnitude} = \sqrt{R^2 + I^2}$$

Where:

R is the real number stored at Register Address 0x94 and Register Address 0x95.

I is the imaginary number stored at Register Address 0x96 and Register Address 0x97.

For example, assume the results in the real data and imaginary data registers are as follows at a frequency point:

Real data register = 0x038B = 907 decimal

Imaginary data register = 0x0204 = 516 decimal

$$\text{Magnitude} = \sqrt{(907^2 + 516^2)} = 1043.506$$

To convert this number into impedance, it must be multiplied by a scaling factor called the gain factor. The gain factor is calculated during the calibration of the system with known impedance connected between the VOUT and VIN pins.

Once the gain factor has been calculated, it can be used in the calculation of any unknown impedance between the VOUT and VIN pins.

2) Gain Factor Calculation:

An example of a gain factor calculation follows, with the following assumptions:

Output excitation voltage = 2 V p-p

Calibration impedance value, ZCALIBRATION = 200 kΩ

PGA Gain = X1

Current-to-voltage amplifier gain resistor = 200 kΩ

Calibration frequency = 30 kHz

Then typical contents of the real data and imaginary data registers after a frequency point conversion are:

Real data register = 0xF064 = -3996 decimal

Imaginary data register = 0x227E = +8830 decimal

$$\text{Magnitude} = \sqrt{(-3996)^2 + (8830)^2} = 9692.106$$

$$\text{Gain Factor} = \left(\frac{\text{Admittance}}{\text{Code}} \right) = \left(\frac{\frac{1}{\text{Impedance}}}{\text{Magnitude}} \right)$$

$$\text{Gain Factor} = \left(\frac{\frac{1}{200\text{k}\Omega}}{9692.106} \right) = 515.819 \times 10^{-12}$$

3) Impedance Calculation using Gain Factor contain the following data:

Real data register = 4630 decimal
Imaginary data register = 8857 decimal

Magnitude= 9994.16

Then the measured impedance at the frequency point is given by

$$\text{Impedance} = \frac{1}{\text{Gain Factor} \times \text{Magnitude}}$$

$$\text{Impedance} = 220.00\text{K}\Omega$$

IV. EXPERIMENTAL RESULTS

A.) AD5933 Calibration result

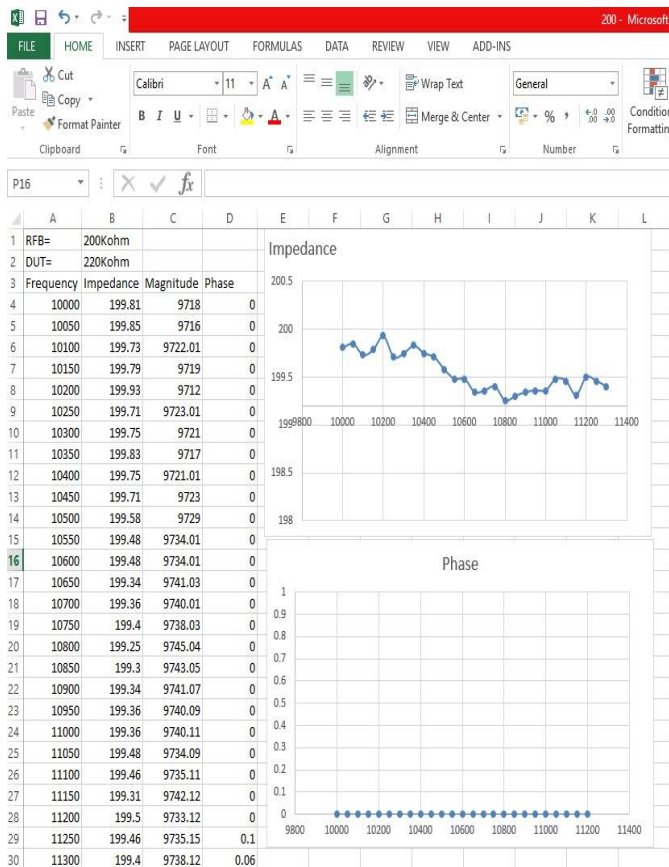

Fig 5 : calibration result

The AD5933 should be calibrated using known impedance the calibrate unknown impedance. The result will be show follows in the serial monitoring of Arduino IDE.

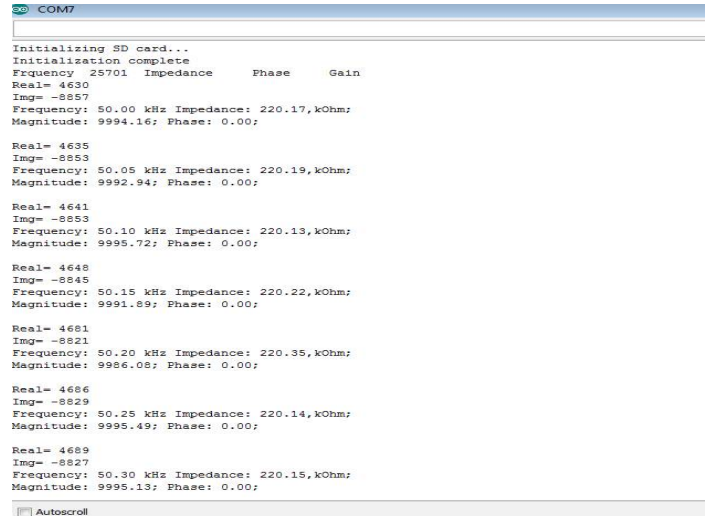

Fig 6 : impedance result

V. CONCLUSION

The impedance measurement system was studied in this paper work. A system is designed by using Arduino mega board and AD5933 impedance converter IC. The microcontroller was used for controlling and programming the AD5933 IC such generating sine wave up to 1-100 KHz range for oscillating the output voltage on the output pin of AD5933 as we saw in the system. The development board is shield of Arduino mega board which computing the impedance of device under test. The user can be measured the impedance of complex electrical system.

Future Scope:- The available impedance analysers are basically very expensive and which are not suitable for application based but only general purposed system. According available impedance analyser the proposed system is very easy to measure the impedance of unknown device which device is generally used in the electronics system.

References

- [1] AD5933 Impedance converter datasheet, www.analog.com
- [2] Yaowen Yang and Aiwei Miao "effect of external vibration on pzt impedance signature" Sensors 2008, 8, 6846-6859; DOI: 10.3390/s8116846
- [3] Yaowen Yang, Yuhang Hu and Yong Lu "Sensitivity of PZT impedance sensors for damage detection of concrete structures" Sensors 2008, 8, 327-346.
- [4] Konrad Chabowski, Tomasz Piasecki, Andrzej Dzierka, Karol Nitsch "simple wide frequency range impedance meter based on ad5933 integrated circuit" Metrol. Meas. Syst., Vol. XXII (2015), No. 1, pp. 13–24.
- [5] Operational amplifiers rail to rail AD8606 IC. www.analog.com